



The **COMPACT NEXT> line** represents the latest test platform, offering configurability and customization for in-line or manual automated In Circuit Test (ICT), flash programming, functional/EOL and Run-in test.

## COMPACT LINE DESIGN & WCM APPLICATION

Seica plants adopt the **World Class Manufacturing (WCM)** guidelines to improve the production process from ergonomics and safety of the work area, maintenance and the quality control system.

Particular attention is paid to:

- Safe working environment
- Safe handling and disposal of waste
- Standardized procedures and methods
- Innovation
- Growth of productivity



**Seica's innovative compact NEXT> line** is engineered to facilitate maintenance and includes features designed to minimize or eliminate potential causes of downtime. All of the gauges and indicators for system service (compressed air, network inlets, current plugs) are placed for easy monitoring by the operator. Moreover, air conduits for cooling, protection of the electronics from dust and water, and service inlet are protected against accidental impacts.

## A COMBINATION OF INNOVATION, HIGH PERFORMANCE, FLEXIBILITY AND THROUGHPUT

Designed for high configurability, the compact line, based on **Seica's NEXT> platform**, meets the most different test requirements, allowing the user to choose the configuration that best suits the application. **One of the main features of the NEXT> platform is the possibility to provide the best integration of technology and easiness of use.**

- Seica offers a turnkey solution where the following tests are automatically combined together in a production line based on the demand:
- In Circuit Test (ICT): Open/Short, R/L/C, Diodes, Transistors, FETs, regulators etc.
- OBP (On-board programming)
- Power ON and Functional (FUN) Test through CAN/LIN Interface etc.
- LED Test with sensors
- EOL Test
- RUN-IN Test
- Interactive Communication with Customer's MES (Manufacturing Execution System)

The compact NEXT> is specialized in **configurations for synchronous and asynchronous parallel test** according to the user's production requirements. All of the Compact systems can be configured in multi-receiver and multi-job arrays to test up to 4 boards at the same time, ensuring:

- Drastic Test time reduction;
- Improved test throughput;
- Overall test cost reduction,
- More intensive use of instruments.



## POWERFUL HARDWARE LOGIN CORE

The engineering core bound to the system features the ACL and the iFUN modules designed to respond to both in-circuit and functional test requirements. The ACL module is based on DSP technology and uses independent D/A and A/D converters for each synthesized instrument. Measurements are fast, accurate and repetitive. Each ACL module hosts 3 independent Arbitrary Waveform Generators (AWG), a Multimeter, a Timer-Counter, a large on-board memory and processing capability to enable signal processing and digital scope functionalities.



The iFUN is a base module for AWG (Arbitrary Waveform Generator) and/or DIGITIZER (Sampling Card) boards; it has a 4-quadrant grounded DC Voltage Generator with fixed current limit and 16-bit resolution. The DIGITIZER is a 16-bit sampling board. Controlled by the system PC through the high-speed and high-bandwidth fiber optic bus, the test backplane hosts digital and analog matrix cards and internal instruments.



## Compact NEXT> - MAXIMUM CONFIGURABILITY AND FLEXIBILITY

### COMPACT MULTI



It is the **ideal solution** for all mixed **ICT, pre-functional, functional, EOL and RUN-IN test**. The versatility and scalability make the **COMPACT Multi NEXT>**, the perfect test system suited for the integration of external instrumentation, capabilities and techniques in a single test program.

#### Analog and Digital channels capabilities

- Power channels capabilities
- Optional Software in-circuit capabilities
- CAN, LIN, K-line, GPIB interfaces
- Pneumatic or Manual fixture receiver integrated
- Multiple programmable power supplies
- Resistive loads modules option
- High voltage/current capabilities
- 19" internal rack for instrument integration
- Parallel test option (max 4 jobs)
- On Board Programming (OBP) capabilities
- Radio Frequency (RF) Test up to 5G
- Digital channels up to 10 MHz
- Openfix capabilities



In response to the growing demand for compact, flexible and seamlessly integrated solutions in today's manufacturing landscapes, Seica offers other system solutions that can be adapted to any application: **COMPACT NEXT> TK and CUBE**.

## COMPACT SL



The **COMPACT SL NEXT>** configuration offers a completely automated solution via an integrated, **SMEMA** compatible transport system, allowing completely automatic board handling and easy integration into high volume production lines. This automated system for in-line integration is perfect for ICT, pre-functional, functional and RUN-IN Test.

- SMEMA compliant in-line or stand-alone solution
- Up to 2048 Analog Channels
- Digital channels up to 10 MHz
- Openfix capabilities
- Up to 16 user power supplies
- Parallel test option (max 4 jobs)
- On board programming features
- GPIB, RS232, CAN, and other protocols management
- Motorized fixture receiver
- 19" internal rack for instrument integration
  - In-line robot integration
  - Very handy and ergonomic: 450 mm width
  - Up to 640 Analog Channels
  - Functional test expandibility
  - On Board Programming (OBP) test option
  - Boundary scan test option
  - Electrical Press fixture receiver

## COMPACT DIGITAL

**COMPACT Digital NEXT>** is Seica response to the constant demand for testing integrated devices via vector-based techniques and dedicated protocols such as **Boundary Scan**, without excluding the need to combine the in-circuit test as well.

- Analog, Digital and Hybrid channels capabilities
- ICT (In Circuit Test): Open/Short, R/L/C, Diodes, Transistors, FETs, regulators
- Up to 1536 Analog Channels
- Functional testing
- On Board Programming (OBP) test option
- Boundary scan test option
- Digital test pattern



## COMPACT RT



Seica meets the needs of the continuous driving market trend of Electronics PCBs miniaturization with the new **COMPACT RT NEXT>**. It is a fully automatic Rotary Table based system, ideal for medium/high volume production. It has been designed to provide immediate in-line robot integration to reduce the impact of DUT loading/unloading times. The first tangible sign is that the rotary table gives the benefit to save the loading/unloading time.

- Very handy and ergonomic: 450mm width
- Functional test expandability
- Rotary table
- Electrical Press fixture receiver
- Boundary scan test option

## COMPACT LR

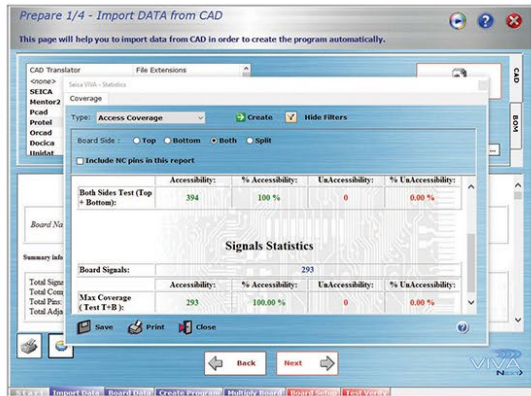

Designed for high configurability, the compact Line, based on **Seica's NEXT> platform**, meets a vast range of test requirements, allowing the user to choose the configuration that best suits the application. **The Compact LR** extends this concept even further, providing legacy replacement capabilities for customers looking to replace test systems which are no longer supported by the original manufacturers, enabling the redeployment of existing fixtures, in particular legacy Aeroflex/Marconi and Teradyne Spectrum 8851 and 8852 fixtures, onto a modern platform which includes all of the technologically advanced performances required by new applications, while at the same time allowing developers to continue to use their traditional standard fixture design.

**Seica's NEXT> platform** includes an extensive range of different test hardware and software tools which can be **combined with the Compact LR** to satisfy all types of requirements, including: analog, digital in-circuit test, dynamic digital test, power-on functional test, boundary scan, LED test, on-board programming.

### TEST PERFORMANCE:

- In-Circuit test
- Functional test
- Advanced Digital Functional Test
- On-Board Programming
- Boundary Scan Test

# VIVA SOFTWARE: THE NEXT GENERATION OF AUTOMATIC TEST PROGRAM DEVELOPMENT

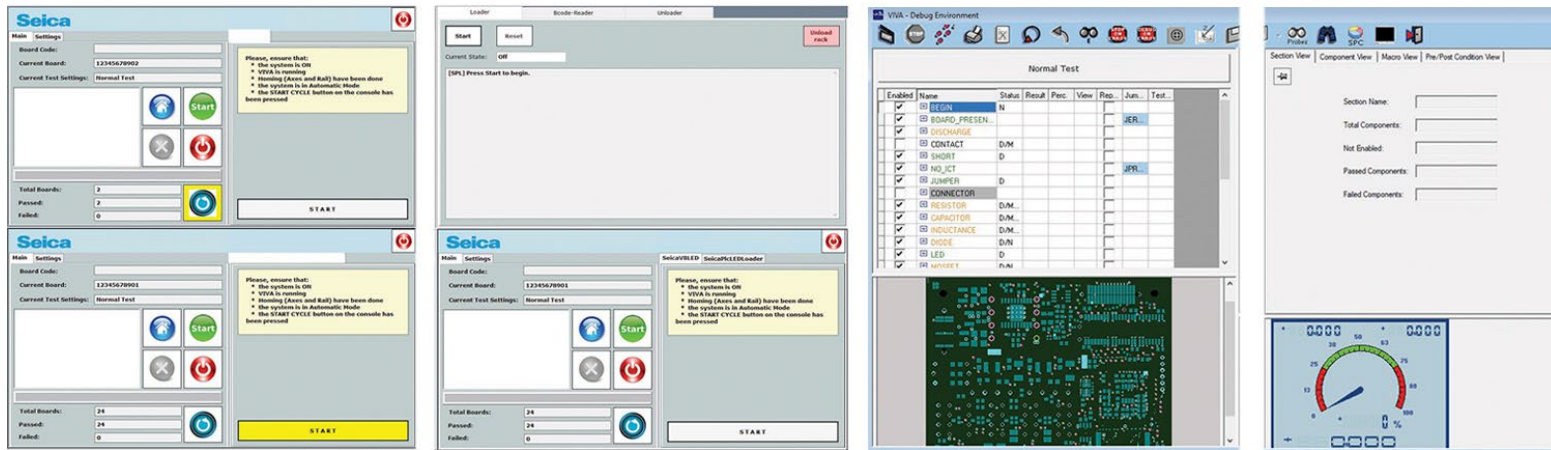

The compact test stations are managed by the Seica VIVA proprietary Software, which is a completely process-oriented test environment, designed to streamline test program development while the functional graphic environment guides the user through a series of automated operations in an intuitive, self-explanatory environment.

The VIVA Software permits an easy and intuitive management of the CAD data, which are directly imported for test generation, validation and diagnostics purposes. Seica provides also advanced Design-for-Test programming solutions for high-mix PCB manufacturing. The new VIVA NEXT> is able to import product data either in its original CAD format, or in the form of machine programs, and convert into optimized test programs in a matter of seconds even for highly complex boards.

This shows the amazing versatility of the NEXT> platform, which ensures that programs developed on other NEXT> systems, can be deployed on the compact NEXT> Series. This means that a program developed on a Pilot test system can be moved without additional efforts to a compact system, allowing the user to optimize production testing according to volume, throughput, test requirements, etc.

Thanks to its unique open architecture, the VIVA software is also compatible with numerous “front-end” packages and allows easy integration of external (.EXE. and .DLL) software modules, as well as third party languages that might better respond to the desire of commonality with tools already in use at the end user plant.

My View is more than a simple graphical user interface (GUI); it is a VIVA software component that allows the customer to:

- Easily create a customizable and localizable MMI using a Seica Graphic Editor.
- Read from and write to the MyView controls at runtime from the external test software sequences.
- Run Python .NET code (IronPython) easily and directly from the external test software sequences.
- Drive all the Hardware modules with the Seica Software suite, external software tool or Python.
- Run the diagnostic test.

The systems can be housed in a variety of ergonomic enclosures that offer different levels of scalability.

## COMPACT NEXT> - FEATURES AND OPTIONS

**ON-BOARD PROGRAMMING (OBP):** Seica offers a fully integrated **On-Board Programming (OBP) solution**, which can be included in any Compact Series system.

Typically, two different programming levels can be adopted in order to meet the different customer needs:

- The fixture-level integration offers advantages in terms of operational costs and speed, but it can be seen as a customized solution for a single family of products.
- The In-System level integration is a universal solution, which can be used to program different devices families. This ensures a flexible yet reliable solution. The maximum configuration allows to program up to 16 devices simultaneously. **SEICA has a library of dozens of available plug-ins**, and also provides development services for custom requirements.



**HIGH VOLTAGE TESTING:** Seica systems can integrate external resources for **High Voltage (HV)** and High-Power Test and Isolation Leakage test and measurements. All the instruments needed for the required measurements are integrated into the test rack containing the switching matrix and backplane. **Seica also provides the recommended safety practices and cooling systems** in regards to the High Voltage and high-power tests.

The considerations concerning safety in electrical testing apply not only to personnel, but also to the test equipment and apparatus or system under test.

**BOUNDARY SCAN:** The VIVA Software is able to drive a Boundary Scan component through the Virtual Bed of Nails (VBN) capability developed by SEICA, which is useful to increase test coverage using the pins of the JTAG components. The goal is to debug and test boards equipped by huge programmable components (FPGA, CPLD,  $\mu$ P...) using them as simple but powerful digital I/O connectors and ignoring their internal program.

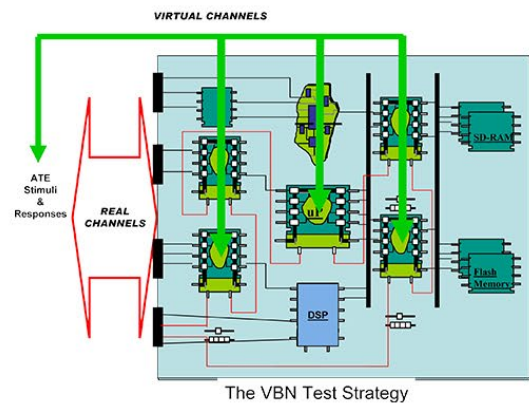
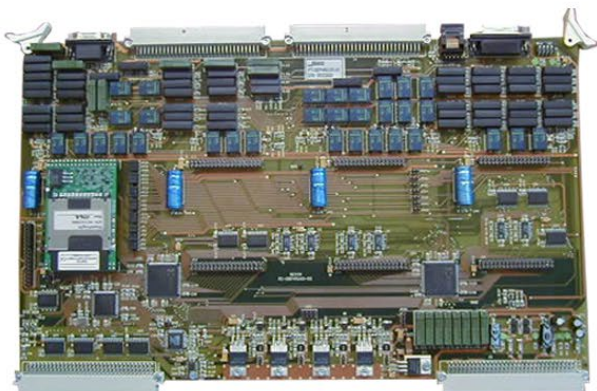

**OPEN FIX TEST:** The **OPENFIX™** module is available for testing today's complex integrated circuits without the need to power up the **UUT**. The dedicated sensors, placed on the IC under test, measure the transmitted **AC signal** to verify for opens; this technique also includes the verification of shorts between adjacent pins. Fast, easy generation of the test and autolearning make for rapid and extremely efficient implementation.

**REPAIR STATION and STATISTICS:** The Repair Station module provides a comprehensive graphic software environment for fault location and repair. Once the test phase has been completed, the operator can recall (either manually or via a barcode reader) and view the faults detected on every tested board, as well as the relevant circuitry connections of the involved components. An intuitive and self-explanatory dialog window displays all the critical points requiring inspection, and allows the operator to enter the information regarding the repair actions performed, which are then stored in a database.

**The QSTAT™** tool uses this database to generate troubleshooting tips and repair information for the operator, and can create reports related to repair activity on the tested boards. The software can be installed either on the test system (local) or on a dedicated PC (remote) networked to the test systems.

The database can collect repair actions on multi-panel boards, on board panels and single boards with no limit on inserted data or dimensions (except for the available space on disk). The SPC Tool enables the statistical analysis of test data, and the generation of CP, CPK and Gauge R&R reports.

**QUICK TEST:** Quick Test™ is a **global Virtual Instrument software interface**, to access all Seica hardware. QuickTest allows the user to graphically interact in real time with the tester hardware and the UUT. The user can easily create test sequences that can be prepared off-line (hardware emulation) or directly executed and viewed.

The results can be stored and become part of the overall test program. QuickTest allows technicians to use any part of the powerful and complex platform of the compact NEXT> Series with the same ease that they use any familiar lab instrument, without requiring knowledge of the system and time-consuming database preparation.

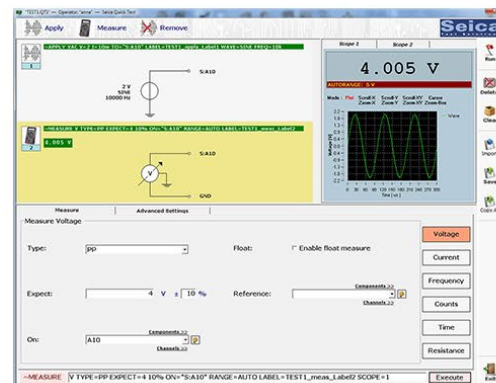
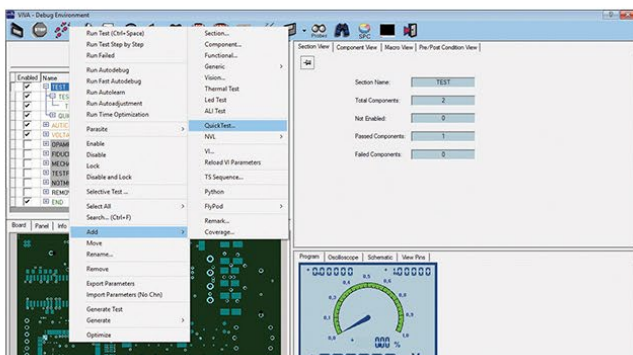

**ACCESSIBILITY and TEST COVERAGE:** Seica can also offer the Test Point Accessibility report, Feasibility Study Report and Coverage Report in order to provide the customer with more information related to the test.

**INDUSTRY 5.0:** Traceability and Industry 5.0 are facing the continuous demand of industrial manufacturing companies to increase the productivity through the digitalization of the manufacturing processes and the collection and processing of data.

The COMPACT line features all of the capabilities needed for implementation in any Factory 4.0 scenario, providing the possibility to plug in any proprietary or third-party information system to achieve the desired goals.



**Seica introduces the Canavisia ShoeBox**, a noninvasive control unit that allows to monitor energy consumption while reducing costs and waste:

- Monitoring of consumption
- Data analysis
- Intervention planning

Thanks to the global extension of Seica and its subsidiaries, Seica can ensure local service support wherever the customer needs it, in addition to 24-hour telephone assistance.



**Seica SPA**  
via Kennedy 24  
10019 Strambino - TO - ITALIA  
Tel: +39 0125 6368.11  
Fax: +39 0125 6368.99  
E-mail: [sales@seica.com](mailto:sales@seica.com)

**Proxima**  
E-mail: [info@proximasrl.eu](mailto:info@proximasrl.eu)

**Seica USA**  
E-mail: [DavidSigillo@seicausa.com](mailto:DavidSigillo@seicausa.com)

**Seica FRANCE**  
E-mail: [dupoux@seica.fr](mailto:dupoux@seica.fr)

**Seica DEUTSCHLAND**  
E-mail: [sales@seica-de.com](mailto:sales@seica-de.com)

**Seica ELECTRONICS**  
(Suzhou)  
E-mail: [seicachina@seica.com](mailto:seicachina@seica.com)

**Seica ISRAEL**  
E-mail: [seicaisraeltd@seica.com](mailto:seicaisraeltd@seica.com)